

Electrolyte trough 1009884

Instruction sheet

10/15 ALF

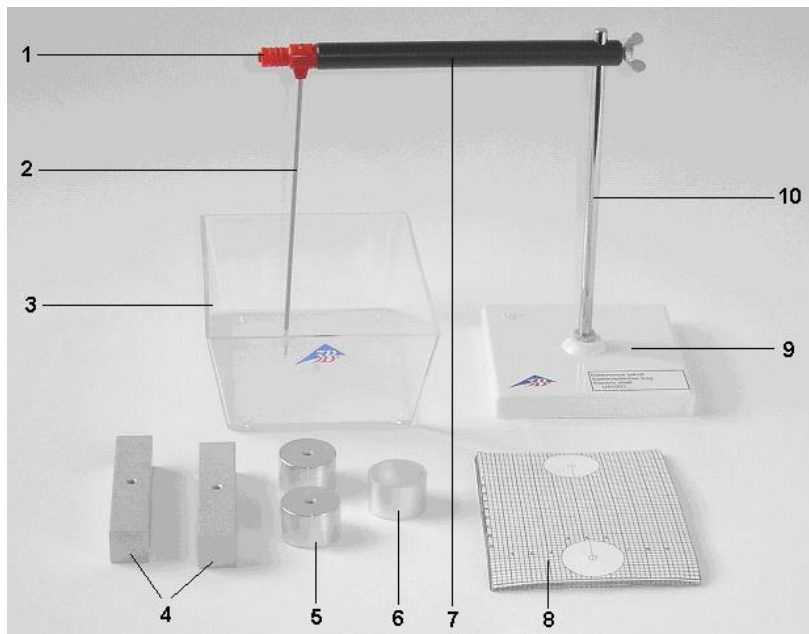

- 1 4-mm safety sockets
- 2 Measuring electrode
- 3 Plastic trough
- 4 Rod electrodes
- 5 Round electrodes
- 6 Aluminum ring
- 7 Insulated cross beam
- 8 1-millimeter squared graph paper
- 9 Stand base
- 10 Stand rod

1. Safety instructions

- After turning on the power, do not touch the electrodes!

2. Description

The electrolyte trough set is designed for recording equipotential field lines of electric fields.

The electrolyte trough consists of a transparent plastic vessel (3) laid on top of 1-mm graph paper (8) and a measuring electrode (2) mounted on a stand. The intention is to find points with identical potential difference. Such points are marked on a second sheet of graph paper and joined up to form equipotential lines.

In order to show a variety of electrical fields, several different shapes of electrode (4/5) are provided.

3. Contents

Plastic trough
 1 Stand with measuring electrode
 2 Rod electrodes
 2 Round electrodes
 1 Aluminum ring (for a Faraday cage)
 20 sheets of 1-mm squared graph paper

4. Technical data

Trough dimensions: 160 mm x 105 mm

5. Principle

Electrical charges generate an electric field, the shape of which can be shown by drawing equipotential lines and surfaces. Since the potential

along these lines or surfaces is always the same, no work is performed if a charge is moved along them. The electric field lines are always perpendicular to the lines or surfaces of equal potential, thus it is only necessary to determine the position of the lines by experiment to determine the lines of the electric field. The form that the equipotential lines take is determined by the spatial arrangement or shape of the electric field generated by the charges.

6. Operation

6.1 Stand assembly

- Attach the stand rod (10) to the base (9) and secure it using the hex nut.
- Attach the insulated cross beam (7) to the stand rod (10) using the wing nut.
- Attach the measuring electrode (2) to the crossbeam by pushing back the connector socket (1) a little and clamping the electrode in place.

6.2 Experiment procedure

Additionally required:

1 AC/DC power supply @230 V	1002776
or	
1 AC/DC power supply @115 V	1002775
1 Multimeter AM50	1003053
2 Pair of Safety Experiment Leads	1002849
400 cm ³ distilled water	

- Place the trough on a sheet of graph paper and set up the experiment as in Fig. 1.
- Connect the power supply across both shaped electrodes and then connect one electrode to the measuring electrode via a voltmeter.

The voltmeter measures the potential difference between one shaped electrode and the measuring electrode mounted on the stand.

- Fill the trough with 400 cm³ of distilled water so that the shaped electrodes are covered.
- The measurement should be performed using 3 to 5 V AC to prevent deposits forming on the electrodes.
- Turn on the power supply and use the measuring electrode to locate points where the potential difference is equal.
- Trace these points on a separate sheet of graph paper and join them together with lines.

In this way, equipotential lines can be traced for various electric fields generated by different-shaped electrodes.

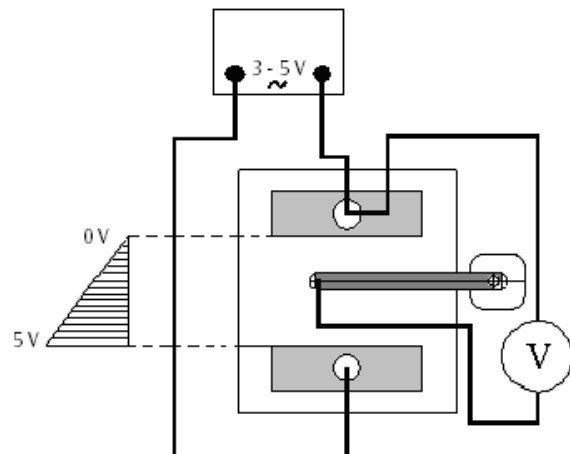

Fig. 1 Experiment set up

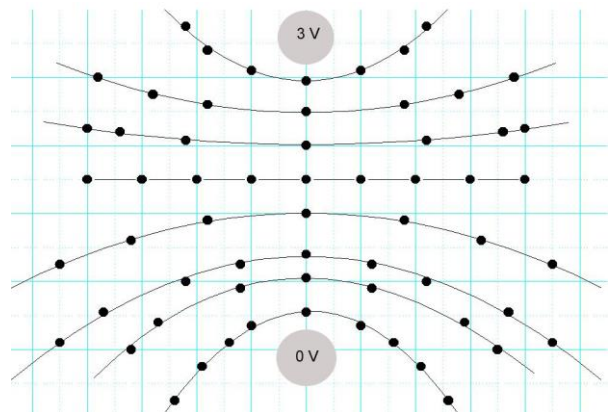

Fig. 2 Equipotential lines for point charges